

SIL SILP

SILENZIATORI CIRCOLARI - CIRCULAR SILENCERS

■ SILENZIATORI CIRCOLARI: SIL-DU/SILP-DU

I silenziatori cilindrici SIL-DU sono disponibili in due versioni, senza ogiva (SIL) e con ogiva (SILP), la presenza dell'ogiva permette una maggiore attenuazione della rumorosità ma genera una perdita di carico nell'impianto (vedi diagramma).

Entrambe le versioni possono essere fissate alla flangia del DUCT corrispondente sia in aspirazione sia in mandata.

Esistono 3 tipologie con lunghezza di 1, 1,5 e 2 volte il diametro (A). Questi silenziatori sono costruiti completamente in lamiera zincata, la parte interna e l'ogiva in lamiera forata e il materiale fonoassorbente in lana minerale.

La temperatura d'esercizio è compresa fra -40 e +150°C e la massima pressione 1000 mm/H₂O.

■ CIRCULAR SILENCERS: SIL-DU/SILP-DU

The cylindrical silencers CCs are available in two versions, without pod (SIL) and with pod (SILP), the presence of the pod allows a greater attenuation of the noise but produces a load loss in the plant.

Both the versions can be fixed to the corresponding flange of the DUCT in inlet and outlet.

It is possible to provide 3 versions with length of 1, 1,5 and 2 times diameter (A). These silencers are manufactured completely in galvanized steel. The internal part and the pod in punctured sheet and mineral wool.

The working temperature is included from -40 and +150°C and the maximum pressure corresponds to 1000 mm/H₂O.

SIL SENZA OGIVA / SIL WITHOUT POD



■ SIL-DU

Attenuazione in dB per banda di ottava (Hz) Spectrum (Hz) of noise attenuation in dB																					
Model	G=1xØ							G=1,5xØ							G=2xØ						
	125	250	500	1K	2K	4K	8K	125	250	500	1K	2K	4K	8K	125	250	500	1K	2K	4K	8K
31	1	3	8	14	9	8	7	2	5	12	19	13	11	8	6	6	16	26	17	13	9
35	0	3	9	14	10	8	6	0	5	12	21	13	11	9	2	6	15	25	16	12	10
40	0	4	10	13	8	8	5	1	5	14	19	12	10	8	2	7	18	24	15	12	9
45	1	4	12	12	9	6	6	1	6	17	17	13	9	8	1	7	21	21	15	10	8
50	0	4	13	11	9	6	5	1	6	18	17	12	9	7	2	8	23	21	14	11	8
56	0	4	14	11	8	5	4	2	7	20	15	11	8	5	1	9	24	19	14	10	7
63	1	5	14	10	9	5	5	2	7	20	14	12	8	6	2	9	25	17	14	10	7
71	1	5	12	9	7	5	5	2	7	18	11	9	6	7	4	9	24	14	11	8	8
80	3	7	9	8	6	5	4	5	10	13	12	9	7	7	6	13	22	14	10	9	7
90	3	7	13	8	6	5	4	5	11	16	11	7	7	5	6	14	23	13	9	7	6
100	3	8	12	8	4	4	4	5	12	17	10	6	6	5	6	16	23	12	7	7	6
112	3	8	13	7	5	4	3	5	12	18	8	6	5	4	6	15	23	10	7	6	6
125	3	9	13	7	4	4	3	6	12	17	8	5	5	4	8	17	22	10	6	6	5

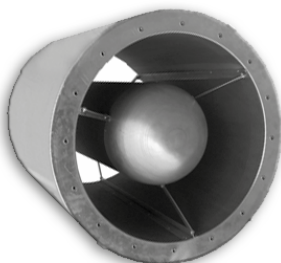

■ SILP-DU

SILP CON OGIVA - SILP WITH POD

Attenuazione in dB per banda di ottava (Hz) Spectrum (Hz) of noise attenuation in dB																					
Model	G=1xØ							G=1,5xØ							G=2xØ						
	125	250	500	1K	2K	4K	8K	125	250	500	1K	2K	4K	8K	125	250	500	1K	2K	4K	8K
31	1	4	9	16	17	13	10	4	5	13	23	26	18	12	6	7	17	32	33	22	17
35	0	4	11	22	21	15	12	1	7	15	33	32	22	17	2	8	19	40	39	27	20
40	1	4	11	20	18	14	11	2	6	15	31	27	19	14	2	9	20	37	35	23	16
45	1	6	14	21	19	13	9	2	7	19	31	28	18	12	3	10	23	39	36	21	15
50	2	5	13	20	16	11	8	3	7	19	29	24	14	10	3	10	24	38	32	18	12
56	1	6	15	21	17	11	8	3	9	22	32	27	15	11	2	12	27	41	35	18	12
63	1	6	15	19	16	10	8	2	9	22	29	23	14	10	3	11	27	37	29	15	12
71	2	7	15	20	18	12	10	3	11	22	31	25	13	11	5	14	29	41	32	18	15
80	3	9	12	17	15	9	8	6	13	18	26	22	12	11	6	16	29	35	26	15	12
90	4	8	15	16	11	8	7	5	12	20	24	16	10	9	7	17	30	34	20	12	11
100	8	14	20	24	21	14	10	10	22	30	37	29	16	12	13	28	39	47	38	19	13
112	6	13	20	21	14	8	7	10	19	29	33	20	11	10	14	26	36	42	24	13	11
125	7	12	18	19	10	6	6	10	18	26	29	14	9	7	13	25	35	37	17	11	9

Modello Model	SIL senza ogiva SIL without pod			SIL CON ogiva SIL with pod		
	kg			kg		
	G=1xØ	G=1,5xØ	G=2xØ	G=1xØ	G=1,5xØ	G=2xØ
31	9	12	15	13	17	21
35	12	16	20	16	22	27
40	15	20	25	20	28	35
45	19	25	31	25	33	41
50	22	30	38	29	39	50
56	25	35	44	34	46	57
63	32	43	54	43	57	72
71	36	49	64	52	71	89
80	47	65	83	66	90	114
90	62	83	104	86	116	145
100	74	98	126	104	141	177
112	91	124	158	129	175	222
125	110	148	188	160	214	268

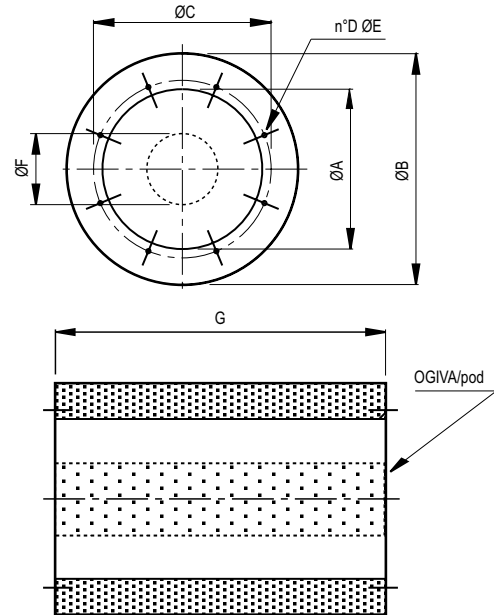

DIMENSIONI - DIMENSIONS

Modello Model	$\varnothing A$	$\varnothing B$	$\varnothing C$	D	$\varnothing E$	$\varnothing F$ (SILP)	G 1xØ	G 1,5xØ	G 2xØ
31	315	455	355	8	M8	140	315	472,5	630
35	355	495	395	8	M8	200	355	532,5	710
40	400	540	450	8	M10	200	400	600	800
45	450	610	500	8	M10	245	450	675	900
50	500	660	560	12	M10	245	500	750	1000
56	560	720	620	12	M10	295	560	840	1120
63	630	790	690	12	M10	295	630	945	1260
71	710	870	770	16	M10	380	710	1065	1420
80	800	1000	860	16	M10	380	800	1200	1600
90	900	1100	970	16	M12	380	900	1350	1800
100	1000	1200	1070	16	M12	650	1000	1500	2000
112	1120	1320	1190	20	M12	650	1120	1680	2240
125	1250	1450	1320	20	M12	650	1250	1875	2500

PERDITE DI CARICO DEI SILENZIATORI SILP-DU

SILENCERS SILP-DU PRESSURE LOSS

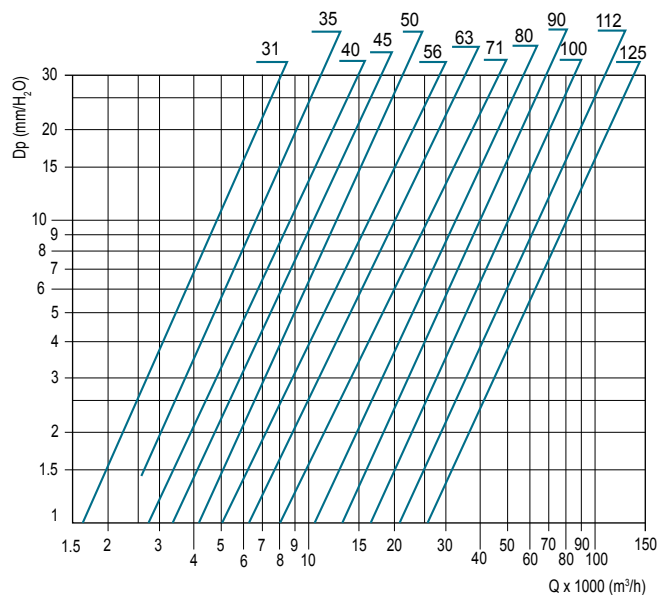

N.B. Versione senza ogiva SIL
perdita di carico irrilevante.
Note : Silencer without pod SIL
loss charge insignifican.

DUCT

ACCESSORI - ACCESSORIES

■ BOCCAGLIO: IN-DU

Permette un maggior rendimento del ventilatore nel caso di bocche non canalizzate. Costruito in lamiera di acciaio, con flangia realizzata a norme UNI EN ISO 13351/Tab.1, per fissaggio alla cassa e una flangia raggiata. Protetto contro gli agenti atmosferici.

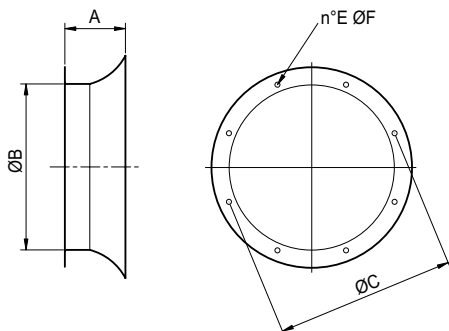

■ INLET CONE: IN-DU

It improves the fan efficiency in case of free inlet or outlet. Manufactured in steel sheet, one flange is designed to be fixed with the fan flange according to UNI EN ISO 13351/Tab.1 standards, and the other flange is round shaped. Protected against the atmospheric agents.

Modello Model	ØA	ØB	C	ØD	E	kg
IN-DU 31	150	310	355	8	10	3,9
IN-DU 35	150	360	395	8	10	4,2
IN-DU 40	150	410	450	8	12	3,3
IN-DU 45	160	460	500	8	12	6,2
IN-DU 50	160	510	560	12	12	7,2
IN-DU 56	160	570	620	12	12	6
IN-DU 63	160	640	690	12	12	9,7
IN-DU 71	180	710	770	16	12	11,8
IN-DU 80	200	810	860	16	12	16,4
IN-DU 90	250	910	970	16	16	15
IN-DU 100	250	1010	1070	16	16	17,7
IN-DU 112	250	1130	1190	20	16	23
IN-DU 125	250	1260	1320	20	16	27,5
IN-DU 140	300	1400	1470	20	16	45
IN-DU 160	300	1615	1680	24	20	53

■ RETE DI PROTEZIONE: FPG-DU

Salvaguardano dal contatto accidentale con le parti in movimento del ventilatore. Realizzate in filo d'acciaio a norme UNI EN ISO 12499, EUROVENT1/3 e protette contro gli agenti atmosferici. (Necessaria nell'utilizzo a bocca libera).

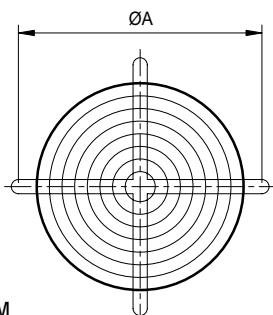

Versione piana per DUCT-M
Safety grid for DUCT-M

■ PROTECTION GUARD: FPG-DU

They preserve from the casual contact with the rotating parts of the fan. Manufactured in steel rod according to UNI EN ISO 12499, EUROVENT1/3 standards and protected against the atmospheric agents. (Necessary for use in free air).

Modello Model	ØA	kg
FPG-DU 31	355	0,6
FPG-DU 35	395	0,7
FPG-DU 40	450	0,9
FPG-DU 45	500	1
FPG-DU 50	560	1,3
FPG-DU 56	620	1,5
FPG-DU 63	690	1,8
FPG-DU 71	770	2,5

Modello Model	ØA	kg
FPG-DU 80	860	3
FPG-DU 90	970	4
FPG-DU 100	1070	5
FPG-DU 112	1190	8
FPG-DU 125	1320	10
FPG-DU 140	1470	14
FPG-DU 160	1680	20

■ PIEDI DI FISSAGGIO: FF-DU

Consentono l'ancoraggio del ventilatore. Realizzate in lamiera d'acciaio e protette contro gli agenti atmosferici.

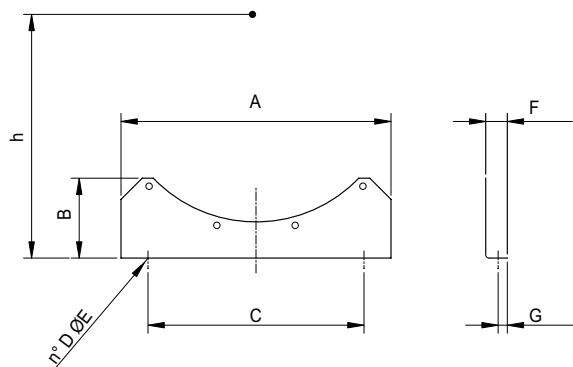

■ FIXING FEET: FF-DU

They allow the fan fixing. Manufactured in steel sheet and protected against the atmospheric agents.

Modello Model	A	B	C	D	ØE	h	F	G	kg
FF-DU 31	350	100	1x250	2	10	245	40	16	2
FF-DU 35	350	100	1x250	2	10	265	40	16	2
FF-DU 40	350	100	1x250	2	10	292	40	16	2
FF-DU 45	350	100	1x250	2	10	317	40	16	2
FF-DU 50	500	200	2x200	3	12	380	40	16	4,6
FF-DU 56	560	215	2x230	3	12	410	40	16	5,6
FF-DU 63	630	230	2x240	3	12	450	40	16	6
FF-DU 71	700	200	2x275	3	12	490	40	16	6,2
FF-DU 80	800	215	2x330	3	12	540	40	16	7,6
FF-DU 90	900	230	2x370	3	12	600	40	16	12,8
FF-DU 100	900	230	2x370	3	12	650	40	16	12,8
FF-DU 112	1120	326	2x460	3	12	710	50	20	19
FF-DU 125	1250	330	2x525	3	12	770	50	20	21,2
FF-DU 140	1400	400	3x400	4	16	870	70	25	37,6
FF-DU 160	1600	510	3x500	4	20	980	70	25	44

DUCT

ACCESSORI - ACCESSORIES

■ CONTROFLANGIA: CF-DU

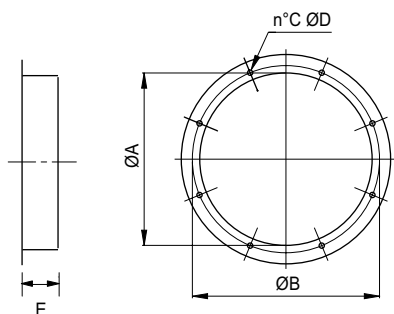

■ COUNTER FLANGE: CF-DU

Modello Model	ØA	ØB	C	ØD	E	kg
CF-DU 31	310	355	8	10	80	1
CF-DU 35	360	395	8	10	80	1,2
CF-DU 40	410	450	8	12	80	1,9
CF-DU 45	460	500	8	12	80	2,1
CF-DU 50	510	560	12	12	80	2,4
CF-DU 56	570	620	12	12	80	2,6
CF-DU 63	640	690	12	12	80	2,9
CF-DU 71	710	770	16	12	80	3,4
CF-DU 80	810	860	16	12	80	3,9
CF-DU 90	910	970	16	16	100	6,8
CF-DU 100	1010	1070	16	16	100	7,4
CF-DU 112	1130	1190	20	16	100	8
CF-DU 125	1260	1320	20	16	100	9
CF-DU 140	1400	1470	20	16	120	18,5
CF-DU 160	1615	1680	24	20	120	21

■ SUPPORTI ANTIVIBRANTI: AV

Sono montati sotto ai piedi di sostegno per impedire la trasmissione di vibrazioni e rumori delle strutture. Sono in metallo-gomma speciale. Sono disponibili altri modelli e tipologie di AV in funzione delle applicazioni. Idonee solo per sollecitazioni di compressione.

■ AV MOUNTS: AV

They are fitted under the support brackets to avoid the transmission of vibrations and rumors of the structures. Made in special metal-rubber. Other models and types of AV mounts are available upon request according to the different applications. Suitable for compression strains only.

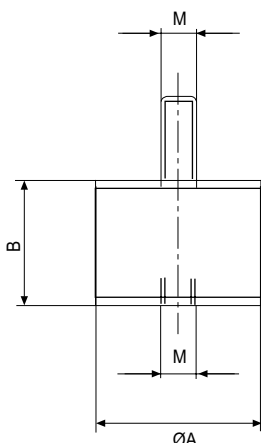

Modello Model	Carico per 1 supporto Load for 1 support	A	B	M	g (weight)
AV 20	10÷20 kg	20	15	6	20
AV 30	21÷50 kg	30	20	8	45
AV 40	51÷65 kg	40	30	8	95
AV 50	66÷130 kg	50	30	10	150
AV 75	220÷340 kg	75	50	12	450

■ GIUNTO ANTIVIBRANTE: FC-DU

Impedisce la propagazione delle vibrazioni sulla canalizzazione. Temperature d'utilizzo -30°C + 80°C. Parti in lamiera protette contro gli agenti atmosferici.

Per temperature diverse sono previste costruzioni speciali.

■ FLEX CONNECTION: FC-DU

Designed to prevent the propagation of the vibrations along the duct. Working temperature -30°C + 80°C. Components in steel sheet protected against the atmospheric agents.

For different temperatures are foreseen special constructions.

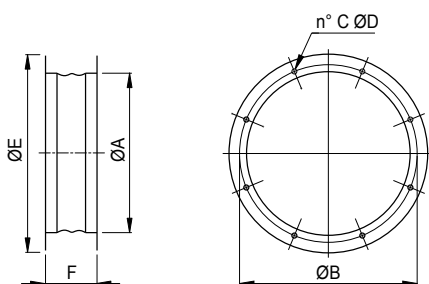

Modello Model	A	B	C	D	E	F	kg
FC-DU 31	310	355	8	10	390	200	2,2
FC-DU 35	360	395	8	10	430	200	2,6
FC-DU 40	410	450	8	12	490	200	4
FC-DU 45	460	500	8	12	540	200	4,5
FC-DU 50	510	560	12	12	600	200	5,2
FC-DU 56	570	620	12	12	650	200	5,5
FC-DU 63	640	690	12	12	725	200	6,2
FC-DU 71	710	770	16	12	805	200	7,2
FC-DU 80	810	860	16	12	910	200	8,3
FC-DU 90	910	970	16	16	1010	220	14
FC-DU 100	1010	1070	16	16	1110	220	15,4
FC-DU 112	1130	1190	20	16	1230	220	17
FC-DU 125	1260	1320	20	16	1360	220	18,5
FC-DU 140	1400	1470	20	16	1520	250	38
FC-DU 160	1615	1680	24	20	1730	250	43