

ROOF-CM EC



NEW

Torrino centrifugo a pale rovesce con motore EC

Centrifugal roof fan with EC motor

APPLICAZIONI

La serie dei torrini centrifughi ROOF-CM EC è costituita da giranti centrifughe a pale rovesce direttamente accoppiate a motori a magneti permanenti a commutazione elettronica (EC). E' particolarmente indicata per estrarre aria dal tetto in ambienti residenziali e commerciali (uffici, negozi, ristoranti) o industriali (capannoni, sale macchine, quadri elettrici...) in cui sia richiesta silenziosità di esercizio, una perfetta regolazione del numero di giri ed un'altissima efficienza con conseguente adempimento alle normative vigenti sul risparmio energetico.

GAMMA

9 modelli diametro girante da 310 a 630mm e con portate d'aria fino a 16.000 m³/h. Pressioni massime disponibili fino a 1400 Pa.

PECULIARITÀ

I ROOF-CM EC sono caratterizzati da un ridottissimo consumo elettrico dovuto all'impiego del motore EC a magneti permanenti con grado di efficienza minimo IE4 (o superiore), da giranti a pale rovesce di design accurato e da un bocchaglio ad ampissimo raggio. Il design particolarmente studiato del cappello conferisce al torrino un'estetica particolarmente gradevole, di facile inserimento in ogni contesto architettonico. La rete di protezione in filo di acciaio offre una resistenza all'aria inferiore rispetto alle reti normalmente presenti sul mercato e un efficace effetto autopulente.

COSTRUZIONE

- Girante a pale rovesce ad alto rendimento in lamiera zincata. Equilibratura secondo UNI ISO 21940-11.
- Base di fissaggio, con bocchaglio aspirante, in lamiera di acciaio protetto contro gli agenti atmosferici.
- Rete di protezione esterna in filo di acciaio protetto contro gli agenti atmosferici.
- Cappello in tecnopolimero.
- Motore elettrico sincrono EC trifase a commutazione elettronica di efficienza IE4 (o superiore), IP55, cl. F.
- Driver monofase o trifase (indispensabile per il funzionamento) fornito non cablato.
- Esecuzione 5 (accoppiamento diretta con girante a sbalzo).

SPECIFICHE TECNICHE

- Aria convogliata: pulita non abrasiva.
- Temperatura aria convogliata: -20°C/+80°C
- Tensione di alimentazione: Versione trifase (T) 400V-50Hz. Versione monofase (M) 230V-50Hz. (Modelli 310, 350, 400)
- Funzionamento solo in estrazione

ACCESSORI

- Serranda a gravità in aspirazione (GS-CM)
- Controbase a murare (CB)
- Basi di appoggio ondulate per torrini (SB)
- Rete in aspirazione (FPG) (necessaria per l'utilizzo a bocca libera)
- Silenziatori in aspirazione (SIL-RO)
- Tastierino esterno con display (RMT)
- Regolatore di velocità 0-10V (SRC 10)

A RICHIESTA

- Versione senza rete
- Versione con cappello in metallo
- Versione senza cappello
- Versione con motore con inverter integrato

APPLICATIONS

ROOF-CM EC line consists of roof fans equipped with centrifugal backward curved impellers directly coupled to an electronically commutated (EC) permanent magnets motor. It is specially suited for air extraction from residential and commercial (offices, shops, restaurants) or industrial (warehouses, engine or electrical rooms,...) buildings in which it is required silent operation and an extremely high efficiency, with fulfillment of the current ErP Regulations on power consumption.

RANGE

9 models with impeller from 310 to 630mm impellers and airflow up to 16.000 m³/h. Maximum pressures allowed up to 1.400 Pa.

ADVANTAGES

ROOF-CM EC fans are characterized by an extremely low power consumption thanks to the use of EC motors with permanent magnets with minimum efficiency grade IE4 (or superior), of backward curved impellers with accurate design and of a very wide and smooth inlet cone. The highly engineered cover grant and aesthetically pleasant installation in every architectural context. The protection grid in steel wire has a much lower aerodynamic impact r compared to standard existing ones, granting better performances and an effective self-cleaning effect.

CONSTRUCTION

- High efficiency backward curved impeller in galvanized steel sheet. Balancing grade according to UNI IS 21940-11.
- Base frame with aerodynamic inlet cone in steel sheet protected against weather agents.
- External protection grid in steel wire protected against weather agents.
- Cover in technopolymer.
- Electronically commutated permanent magnets three-phase motor with minimum efficiency grade IE4 or superior, IP55 Cl.F.
- Mono-or three-phase drive (required for motor running), provided not connected.
- Arrangement 5 (direct coupling)

TECHNICAL SPECIFICATIONS

- Conveyed air: clean not abrasive.
- Temperature of conveyed air: -20°C / +80°C
- Voltage and frequency:
Three phase version (T) 400V-50Hz.
Mono-phase version (M) 230V-50Hz (sizes 310, 350, 400).
- Working only in extraction.

ACCESSORIES

- Gravity shutter (GS-CM)
- Counter-base (CB)
- Corrugated basis (SB)
- Inlet grid (FPG) (necessary for use in free air)
- Inlet silencer (SIL-RO)
- External keypad with display (RMT)
- Speed regulator 0-10V (SRC 10)

UPON REQUEST

- Version without grid
- Version with metal cover
- Version without cover
- Version with motor with built-in inverter

Le prestazioni indicate nei diagrammi si riferiscono ad aria alla temperatura di 15°C ed all'altitudine di 0 mt s.l.m., e sono state ottenute in installazioni di tipo "C" in assenza di reti e accessori.
Performances shown in the selection diagrams refer to air at 15°C temperature and 0 mt a.s.l. altitude, and they were obtained in installation type "C" with no grid nor accessories.

ROOF-CM EC 310

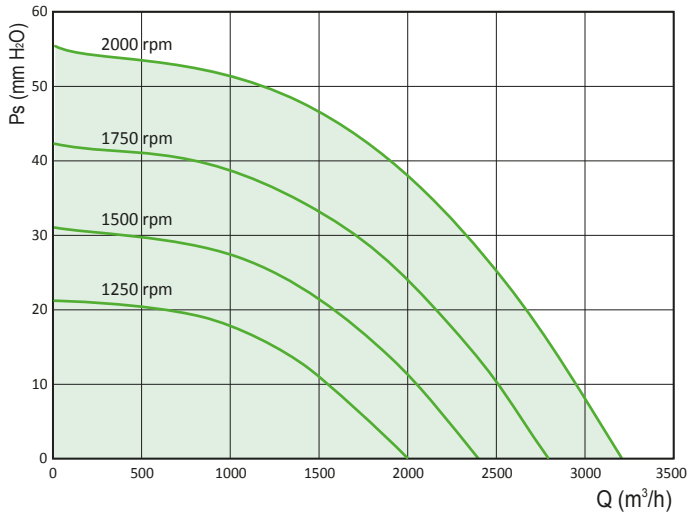

ROOF-CM EC 350

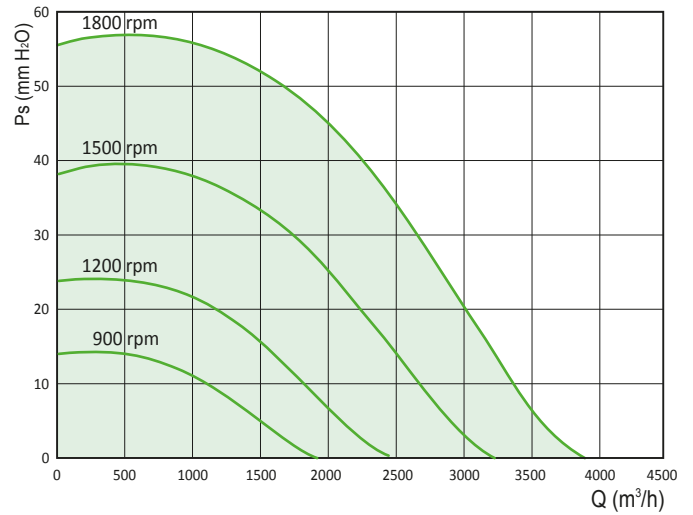

ROOF-CM EC 400

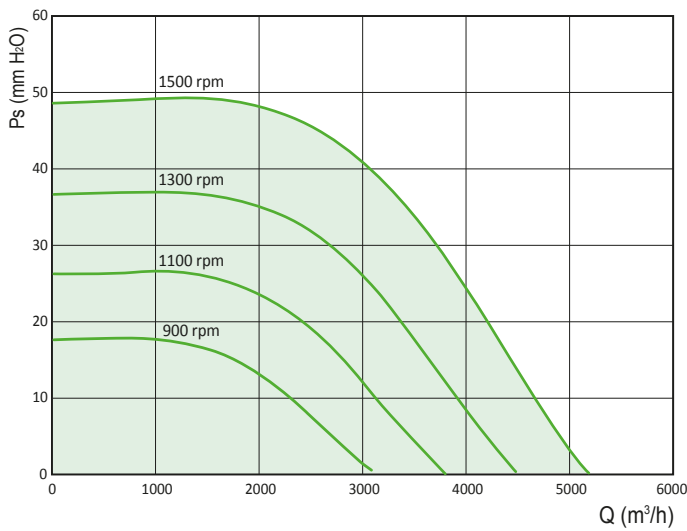

ROOF-CM EC 450

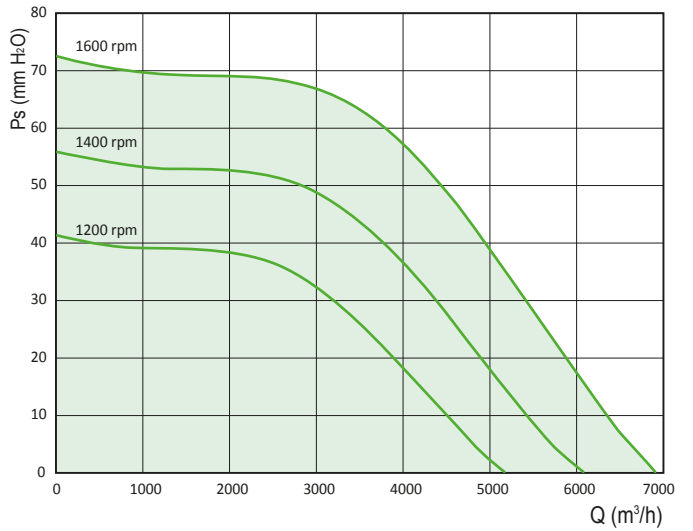

ROOF-CM EC 500

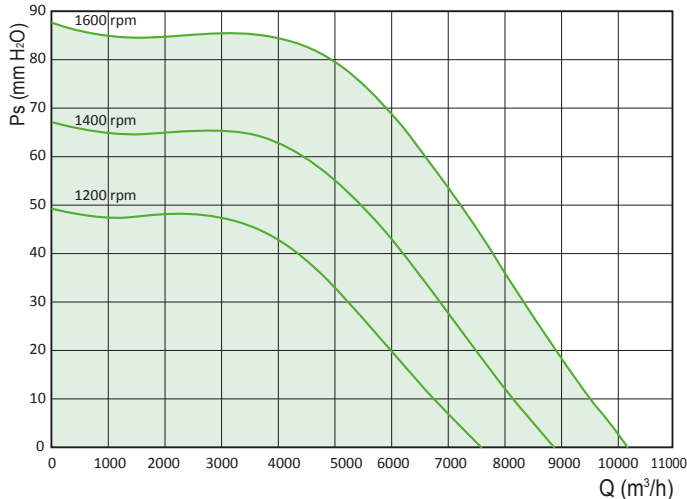

ROOF-CM EC 560

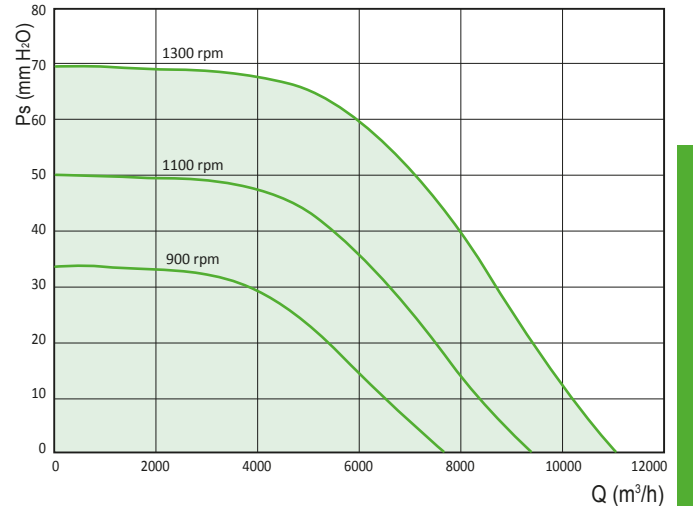

Le prestazioni indicate nei diagrammi si riferiscono ad aria alla temperatura di 15°C ed all'altitudine di 0 mt s.l.m., e sono state ottenute in installazioni di tipo "C" in assenza di reti e accessori.
Performances shown in the selection diagrams refer to air at 15°C temperature and 0 mt a.s.l. altitude, and they were obtained in installation type "C" with no grid nor accessories.

ROOF-CM EC 600/A

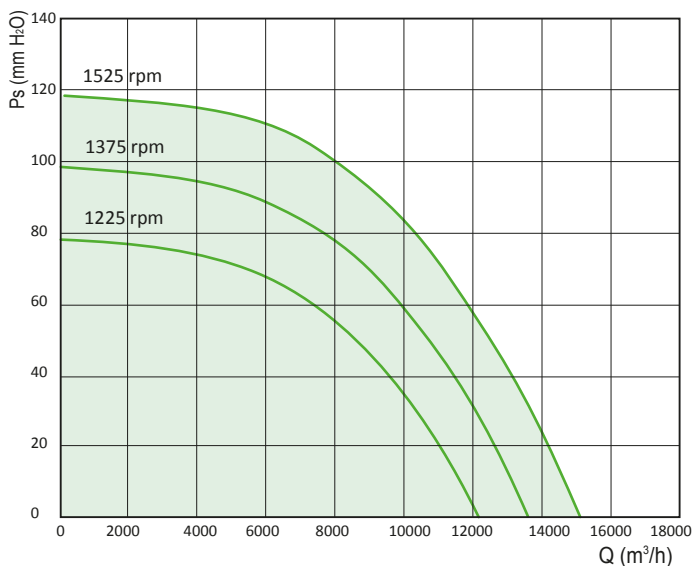

ROOF-CM EC 600/B

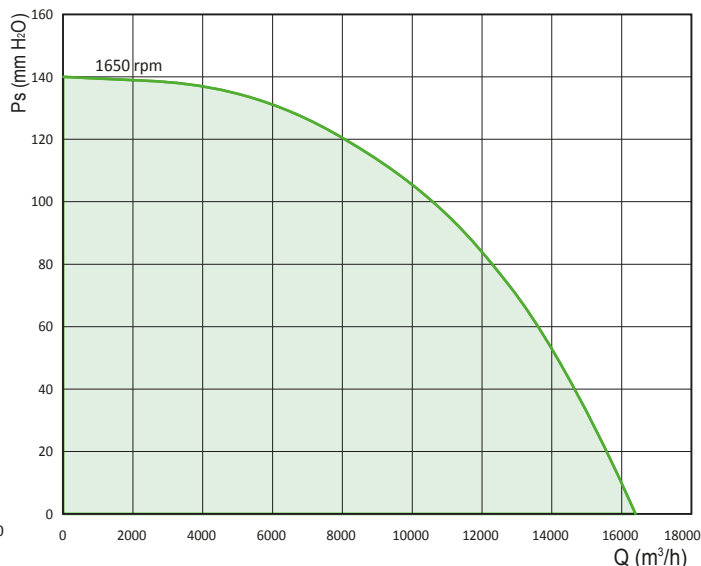

ROOF-CM EC 630

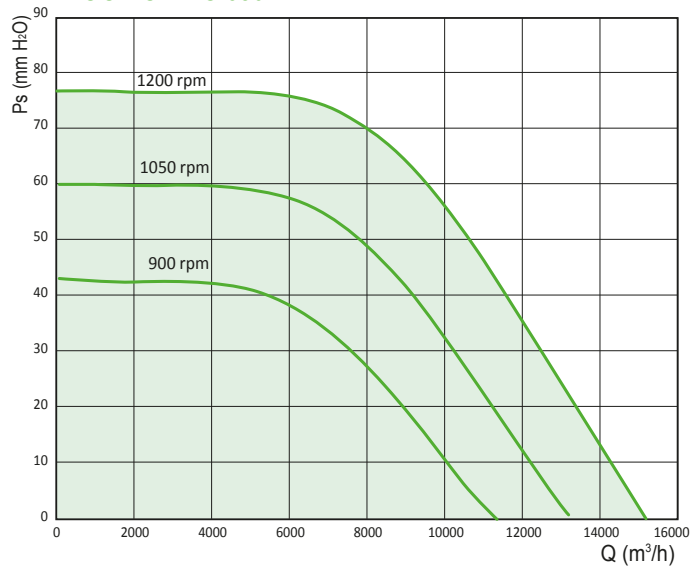

Importante: durante il funzionamento delle macchine accertarsi che la corrente assorbita non superi il valore più basso tra la corrente nominale del motore e dell'inverter (drive).
Important: during use check that the current absorbed never exceeds the lowest value between the rated current of the motor and the rated current of inverter (drive).

Importante: durante il funzionamento delle macchine non superare mai in numero di giri massimo indicato in tabella (*).
Important: during use never exceed the maximum RPM indicated in tables(*).

Tolleranze: prestazioni aerauliche e rumorosità rientrano nelle tolleranze indicate nella norma DIN 24166, Classe 2

Tolerances: performances and sound power levels within the tolerances allowed by the DIN 24166 standard for Class 2.

Modello Model	Alimentazione Supply	RPM fan max (*)	Pr (kW)	Pm (kW/RPM)	In max (Arms)	Lp dB(A)	Drive (kW)
310 M	230V/1	2000	0,3	0,75/1500	3,2	60	0,75
350 M	230V/1	1800	0,3	0,75/1500	3,2	58	0,75
400 M	230V/1	1500	0,4	0,75/1500	3,2	58	0,75
450 T	400V/3	1600	0,9	1,5/1500 ☒ 3,0/3000 △	3,1	61	1,5
500 T	400V/3	1600	1,6	1,5/1500 ☒ 3,0/3000 △	3,1	63	1,5
560 T	400V/3	1300	1,6	3,3/1500 ☒ 6,0/3000 △	6,5	69	3
600/AT	400V/3	1550	2,9	3,3/1500 ☒ 6,0/3000 △	6,5	75	3
600/BT	400V/3	1650	3,6	3,3/1500 ☒ 6,0/3000 △	6,5	77	4
630 T	400V/3	1200	2,2	3,3/1500 ☒ 6,0/3000 △	6,5	68	3

Pm = Potenza motore /Motor power.

Pr = Potenza resa /Shaft power

In = Corrente assorbita / Absorbed current.

RPM = Numero di giri massimi del ventilatore/
Maximum turning speed of the fan.

Lp = Livello di pressione sonora in campo libero a 6 m dal ventilatore con aspirazione canalizzata e mandata libera/ Sound pressure level in free field at 6 m distance from the fan, with inlet ducted and free outlet

Drive = Potenza massima gestita dal drive (inverter)/
Maximum working power of the drive (inverter).

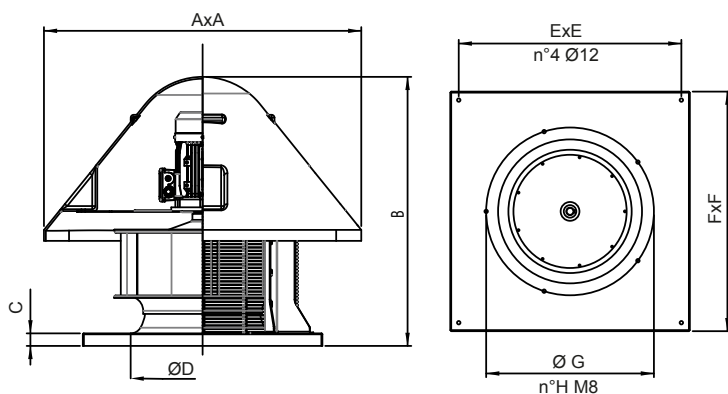

Model	A	B	C	ØD	E	F	ØG	n°H	kg
31	570	490	30	280	360	400	310	3	19
35	670	600	30	300	450	500	330	3	29
40	840	700	35	350	600	650	382	4	43
45	840	730	35	400	600	650	432	4	52
50	1000	840	40	450	710	760	485	5	70
56	1000	880	40	500	710	760	535	5	75
60	1000	900	40	500	810	930	580	6	105
63	1200	980	40	550	870	930	580	6	115

Dimensioni in mm/Dimensions in mm (*) Indicativo/Indicative

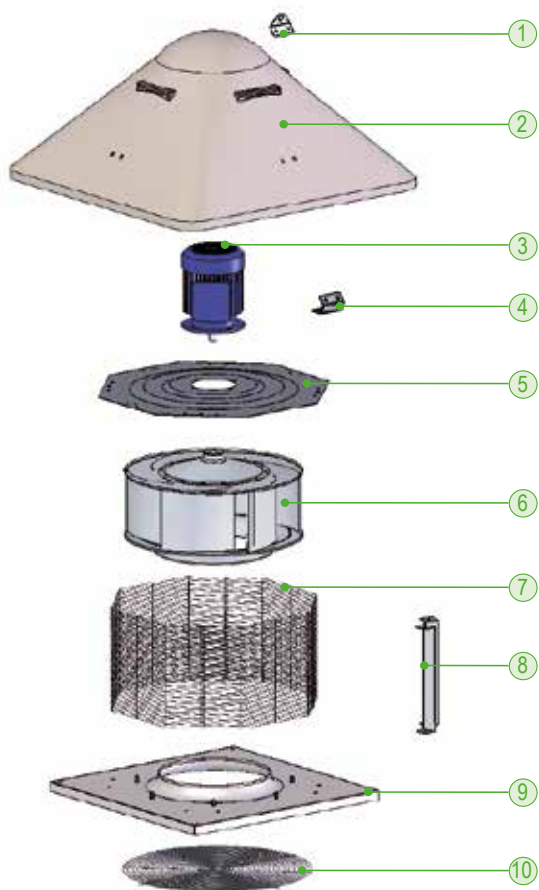

- 1 – Staffe di sollevamento / Lifting brackets
 - 2 – Cappello / Cover
 - 3 – Motore / Motor
 - 4 – Staffe cappello / Cover brackets
 - 5 – Portamotore / Motor support
 - 6 – Girante / Impeller
 - 7 – Rete di protezione / Protection grid
 - 8 – Staffe porta rete / Grid brackets
 - 9 – Base di ancoraggio / Fixing base
 - 10 – Rete di protezione (accessorio)
- Obbligatorio per l'utilizzo a bocca libera
Protection grid (accessory) mandatory for free air



SERRANDA - SHUTTER (GS-CM)

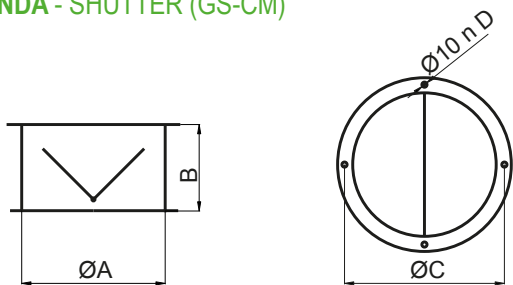

Model	ØA	B	ØC	n*D	kg
GS-CM 31	280	170	310	3	2,2
GS-CM 35	300	180	330	3	3,3
GS-CM 40	350	200	382	4	4
GS-CM 45	400	230	432	4	5
GS-CM 50	450	260	485	5	5,5
GS-CM 56	500	290	535	5	6
GS-CM 60-63	550	310	580	6	8,5

Dimensioni in mm/Dimensions in mm
(*) Indicativo/Indicative

CONTROBASE - COUNTER BASE (CB-CM)

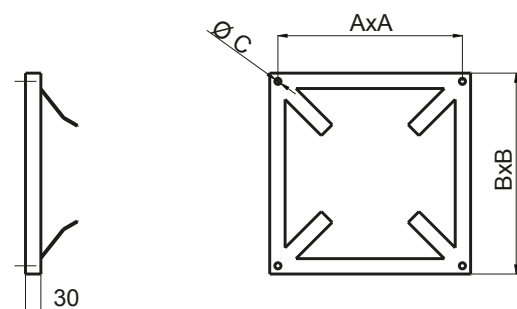

Model	A	B	C	kg
CB-CM 31	360	390	M8	1
CB-CM 35	450	490	M8	1
CB-CM 40-45	600	640	M8	2,8
CB-CM 50-56	710	750	M10	3,3
CB-CM 60-63	870	920	M10	4,2

Dimensioni in mm/Dimensions in mm
(*) Indicativo/Indicative

SILENZIATORE - SILENCER (SIL-RO)

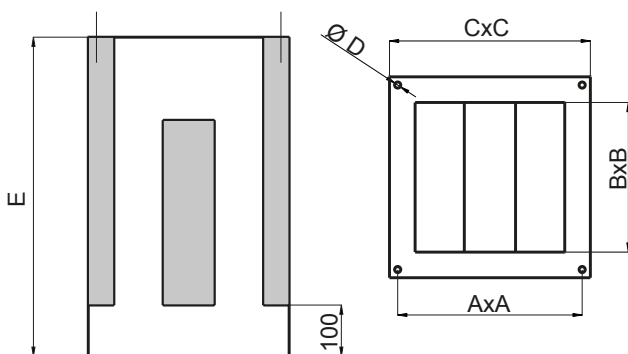

Model	A	B	C	D	E	kg
SIL-RO 31	360	310	390	M8	850	28
SIL-RO 35	450	390	490	M8	850	37
SIL-RO 40-45	600	540	640	M8	850	43
SIL-RO 50-56	710	650	750	M10	850	51
SIL-RO 60-63	870	820	920	M10	1100	80

Dimensioni in mm/Dimensions in mm
(*) Indicativo/Indicative

Hz

Model ROOF-CMV	63	125	250	500	1k	2k	4k	8k
SIL-RO 31	2	4	6	10	16	18	15	11
SIL-RO 35	3	5	9	11	19	20	18	14
SIL-RO 40-45	3	4	8	9	18	15	10	6
SIL-RO 50-56	4	5	11	15	16	12	9	5
SIL-RO 60-63	3	4	5	8	14	9	7	3

Attenuazione in dB per banda di ottava (Hz)
Octave (Hz) spectrum of noise attenuation in dB

RETE IN ASPIRAZIONE - INLET GRID (RA)

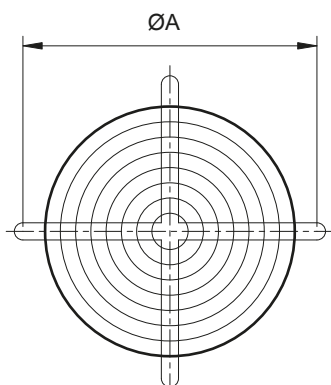

Model	ØA	kg
FPG 31	355	0,6
FPG 35	395	0,6
FPG 40	395	0,7
FPG 45	395	0,7
FPG 50	450	0,9
FPG 56	560	1
FPG 60	620	1,3
FPG 63	620	1,3

Dimensioni in mm/Dimensions in mm

ROOF-CM EC Accessori
Accessories

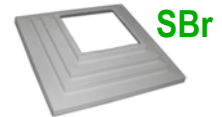
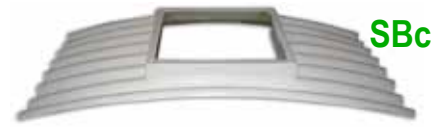
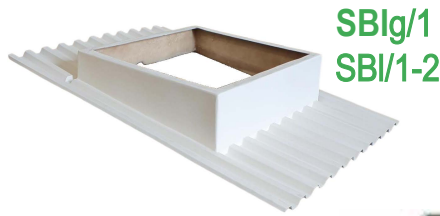

SB Basi d'appoggio ondulate per torrini
Support bases for roof fans

APPLICAZIONI

Le basi d'appoggio ondulate **SB** (converse), realizzate in robusta vetroresina, sono adatte per l'installazione dei nostri torrini su coperture costruite in lastre ondulate, evitando dannosi ristagni d'acqua attorno al ventilatore e costose opere murarie o di carpenteria.

VERSIONI

SBlg/1, SBI/1-2, SBc, SBlp: utilizzabile con torrini aventi basamento 930x930 mm (Modelli 60, 63).

SBr: riduzione da accoppiare con basi **SBlg/1, SBI/1-2, SBc, SBlp** per installazioni torrini 35, 40, 45, 50, 56.

- **SBlg/1:** onda grecata H 28 (passo 112mm altezza 28 mm)
- **SBI/1 10x146:** internazionale (passo 146 mm altezza 48 mm)
- **SBI/2 10x177:** "Euro" (passo 177 mm altezza 51 mm mod.)
- **SBc:** "Euro" (passo 177 mm altezza 51 mm e raggio di curvatura lastra pari a 3 metri
- **SBlp:** caratteristiche come SBI ma con falde (bordi) non ondulati

INSTALLAZIONE

Sovrapporre la conversa alla lastra a valle e sottoposizionarla a monte. Sovrapporsi di almeno un'onda e un quarto con le lastre laterali attigue (mod. **SBlg/1, SBI/1-2, SBc**). Verificare di non avere sovraccaricato eccessivamente la conversa.

APPLICATIONS

The support bases **SB** (valleys), manufactured in sturdy glass-resin, are suitable for the installation of our roof fans on overlays built in corrugated slabs, avoiding detrimental stagnations of water nearby the fan and costly masonry or carpentry works .

VERSIONS

SBlg/1, SBI/1-2, SBc, SBlp: to be used with roof fans having bases 930x930 mm (Models 60, 63)

SBr: Adaptor to be coupled with soaker bases **SBlg/1, SBI/1-2, SBc, SBlp** for installation of roof fans models 35, 40, 45, 50, 56.

The versions SB are suitable to be coupled to corrugated slabs with pitch slope type:

- **SBlg/1:** trapezoidal wave H 28 (pitch 112mm height 28 mm)
- **SBI/1 10x146:** International type (pitch 146 mm height 48 mm)
- **SBI/2 10x177:** "Euro" type (pitch 177 mm height 51mm)
- **SBc:** "Euro" type (pitch 177 mm height 51 mm) and radius of curvature of the sheet of 3 meters.
- **SBlp:** similar features to SBI but with flat edges (not wavy)

INSTALLATION

Overlap the valley to the slab downstream and under-place it upstream. Overlap not less than one and fourth wave with the lateral adjacent slabs (mod. **SBlg/1, SBI/1-2, SBc**).

Verify not to have excessively overloaded the valley



SBlg/1

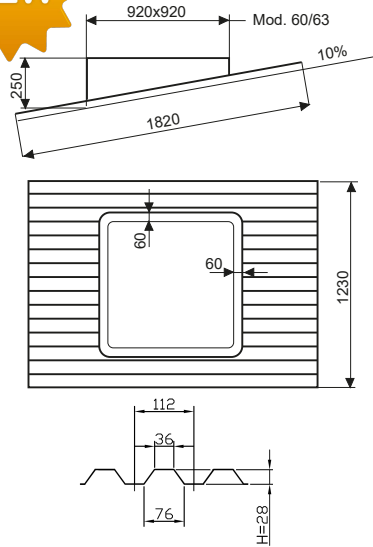

SBI/1-2

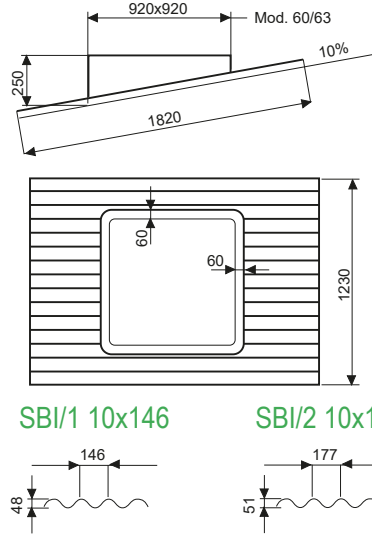

SBc

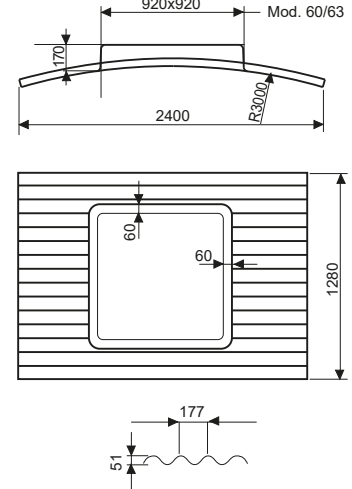

SBlp

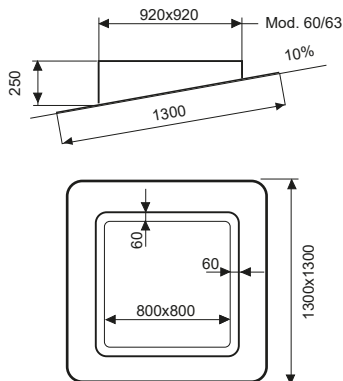

SBlg/1 SBI/1-2 SBc SBlp

per/for mod. 60-63



con/with **SBr** per/for mod. 35-40-45 50-56

SBr

